



**HC FORKLIFT AMERICA CORPORATION**

**Company address:**  
10405-A Granite Street  
Charlotte, NC 28273

Toll Free: (888) 652-8395  
Phone: (980) 888-8335  
Fax: (980) 888-8336

[america@hcforklift.com](mailto:america@hcforklift.com)  
[www.hcforkliftamerica.com](http://www.hcforkliftamerica.com)



2021 VERSION 1 / COPYRIGHT 2021

HANGCHA GROUP CO., LTD. reserves the right to make any changes without notice concerning colors, equipment, or specifications detailed in this brochure, or to discontinue individual models. The colors of trucks, delivered may differ slightly from those in brochures.



## XC Series 4-Wheel Electric Pneumatic Forklift with Lithium-ion Technology

with capacities of 8,000 to 11,000lbs

***Making Material Handling Easier***  
SINCE 1956



# INNOVATIVE SOLUTIONS NEW POWER NOW

Hangcha has extended the load capacity range of the XC Series lithium-ion forklifts to 11,000lbs. Designed around the battery, these forklifts offer a stable, high power, reliable, and maintenance-free alternative to the traditional core IC forklifts.

- / Lithium-ion technology (Lithium Iron-Phosphate), was developed jointly by HANGCHA and CATL for use in material handling equipment applications. These innovative and reliable battery cells and modules are manufactured to the highest standard by CATL exclusively for HANGCHA's forklift line.
- / Rapid and opportunity charging ensures continuous availability of the material handling equipment.
- / Lightweight design, highly efficient, maintenance-free, and a long service life are all benefits of the XC series.
- / The newly designed chassis has a low center of gravity allowing the operator to feel stable while turning the forklift.



## Large Capacity CATL Battery Packs

- / Integrated Battery Management System (BMS) continually monitors energy management and ensures reliable operation.
- / HANGCHA provides these Lithium Iron Phosphate (LiFePO<sub>4</sub>) battery packs with up to a 10 year or 20,000 hour warranty.
- / See warranty certificate for specific warranty information on the Lithium Iron Phosphate battery packs.

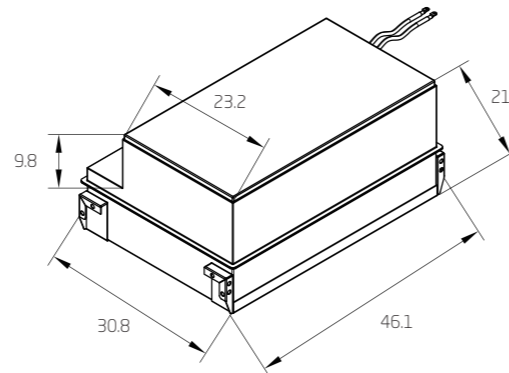

| Battery Options                | Standard               | Optional  |
|--------------------------------|------------------------|---|
| Battery Capacity (V/Ah) (kW·h) | 80V/542Ah<br>43.36kW·h | 80V/813Ah<br>65.04kW·h<br>(Dual Charging Ports Charger) |

## Excellent Ergonomic Design

- / These forklifts are designed to have an operating space more than **50%** larger than a traditional electric forklift.
- / The 4" color LCD instrument panel in the driver's cab is positioned overhead and can be seen when the driver lifts their head. This also allows for easy access to the function buttons.
- / The ergonomically designed tilt-adjustable small-diameter steering wheel combined with a seat with 8.3" of adjust-ability allows the operator to find their optimal driving position. This allows the operator to be more productive.
- / The large brake pedal and regenerative braking function effectively reduces driver fatigue.



## Advantages



*The rear axle connects to the newly designed chassis via a floating suspension system. The floating suspension system, combined with the MOSFET controller automatically decelerating while turning, improves stability and operator comfort.*

*The noise can be as low as 73dBA.*

The MOSFET integrated control system ensures smooth and accurate driving and lifting control. It also provides excellent speed regulation, regenerative braking, reverse braking, and anti-sliding on ramps. The MOSFET integrated control system adds to the safety and reliability of the XC series forklifts.

The high power AC traction motor bolts to the chassis via a bridge-type structure for increased stability.

The controller, connectors, battery plug, and emergency switch are all parts from industry known suppliers to ensure reliability, performance, and ease of service.

# RELIABLE TRUCKS



HANGCHA PROVIDES UP TO A 10 YEAR OR 20000 HOUR GUARANTEE ON THE LITHIUM-ION BATTERY PACKS.



**10 YEAR WARRANTY**

## Easy to Operate and Maintain

The hood and side plates fully seal to protect all of the forklift's major components, including the electrically controlled components, motors, electrical components, etc., from dust and water.

Although the drive motor is low to the ground to help with the forklift's center of gravity, it still is waterproof. This substantially increases the forklift's reliability.

The battery packs can be easily removed by a manual or electric pallet jack.

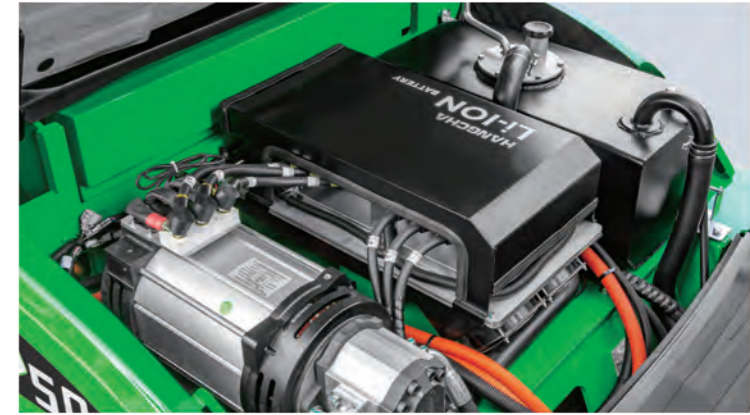

The XC Series forklifts have a IPX4 water resistance rating making them suitable for outdoor operation



The hood, with a self-locking gas strut, can be opened at a large angle to facilitate easy maintenance of the forklift's systems.



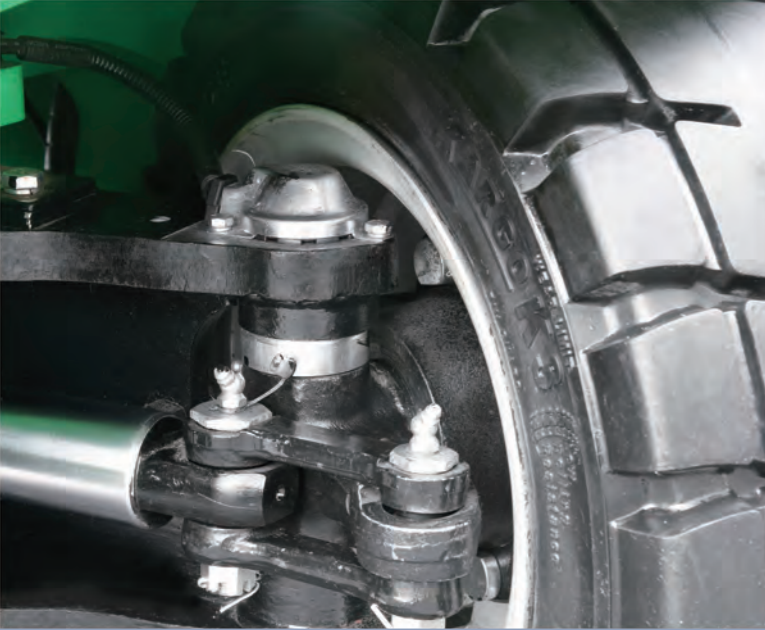

## Safety

The emergency cut-off switch is equipped as apart of the standard configuration.

The standard configuration provides a fork descending buffering function (soft landing feature). In addition, an optional electronic control function for buffering the fork when lifting is provided to protect the goods from falling and damaging the ground.

The optional descending lock function disables the mast from descending when the operator leaves the forklift's seat.

The optional alarm buzzer for the handbrake prompts the operator to pull up the handbrake before leaving the truck.



The XC Series forklifts can have up to three horn buttons. The driver's steering wheel (standard), Grammer fingertip control armrest (optional) and rear reverse grip horn button (optional) are all used for alerting and protecting people in the surrounding area.



The XC Series forklifts have a PIN code system for safety and security. 99 sets of PIN codes are available for the administrator to assign to keep irrelevant personnel from starting the forklift.



Optional Dual Charging Ports



Quick Charge in < 2 hours by plugging two chargers into the optional dual charging ports.



## Comfort

Thanks to the low center of gravity, good stability, and controller functions, the operator can comfortably turn the forklift.

The forklift is equipped with the soft landing system. When the forks are 4.0"-2.4" away from the ground, the mast automatically slows the forks' decent down. This prevents the goods and pallet from slamming into the ground and effectively protects the goods, warehouse floor, and forklift from damage.

The controller interface is conveniently placed so that the operator can easily see and adjust the functions of the forklift.

The forklift is quiet, releases no harmful air pollution, and doesn't use acid in the battery packs. This creates a more comfortable working environment for the operators.

The optional Grammer Fingertip Control Armrest allows the operator to easily control the forklift. It features an emergency shut-off switch, horn, and quadruple thumb switches for convenient operation. Because they function using CAN Bus, the fingertip controls are highly reliable.



The optimized design of the wide-view mast and large opening fork carriage provide the operator with an unobstructed view to the tips of the forks. This promotes a safer operational environment.



Optional Grammer Fingertip Control Armrest

## Efficiency

Thanks to lithium-ion technology, this forklift features opportunity charging. This means that the forklift can work through several shifts, charging during breaks, without needing to stop for hours to recharge. Combined with regenerative braking during deceleration, the powertrain is designed with efficiency in mind.

An ultra-high power AC pump motor is used. The system is highly efficient and offers complete protection functions, built-in speed sensors, and temperature sensors to greatly improved the reliability and life span of the motor.



## Standard Specification

- / High Power AC Drive Motors
- / Solid Pneumatic Tires
- / High Power AC Hydraulic Pump Motor
- / Silent Gear Pump
- / Multi-Function Color LCD Instrument Display
- / Large Integral Rubber Pedal Pad
- / Stamped Iron Hood & Side Plates
- / Stamped Stainless Steel Non-Slip Step
- / The Gas Hood Strut with a Touch-Proof Mechanism
- / Handbrake with a Touch-Proof Mechanism
- / Turning Deceleration Function
- / Smart Cloud Module
- / Soft Landing Forks
- / SPE Controller Power Selection
- / Mileage & Operating Time Display
- / Integrated Fuse Box
- / Charging Muzzle that meets Safety Standards
- / DC-DC converter
- / Electronic Cooling Fan
- / DoubleT Multi-Way Valve
- / Emergency Cut-Off Switch
- / Backup Alarm
- / Tow Pin
- / Tool Box & Clipboard
- / Load Sensing Steering System
- / Standard Limited Free Lift 2 Stage Mast
- / Lithium-ion Battery Packs with Electric Heating Elements
- / LED Combination Headlights, Rear LED Combination Lights, and Three-Color Taillights

## Options

- / Pin Code and Card Entry
- / Non-Marking Solid Tires
- / Left and Right Rearview Mirrors
- / Backup Camera
- / Front & Rear Blue Lights
- / Rear Working Lights
- / Lithium Battery Charger
- / Cold Storage
- / Rear Grip with Horn Button
- / Operator Presence System
- / Triple Multi-Way Valve
- / Quadruple Multi-Way Valve
- / Quintuple Multi-Way Valve
- / Widened / Heightened Load Backrest
- / Widened Fork Carriage
- / Other Dimension Forks
- / Full Free Lift 2 Stage Mast
- / Full Free Lift 3 Stage Mast
- / Side Shifter
- / Other Specialty Options
- / Grammer MSG531 Suspension Seat
- / Grammer Fingertip Control Armrest System

## 8,000lb XC Series Mast Specification

| Type                              | Model      | Max. Fork Height | Lowered      | Overall Height |                  | Free Lift     |                  | Tilting Range |     | Load Capacity<br>8,000lbs at 24" or 600mm |             |
|-----------------------------------|------------|------------------|--------------|----------------|------------------|---------------|------------------|---------------|-----|---|-------------|
|                                   |            |                  |              | With Backrest  | Without Backrest | With Backrest | Without Backrest | F             | R   | Single Tire                               | Dual Tire   |
|                                   |            |                  |              | in(mm)         | in(mm)           | in(mm)        | in(mm)           | (°)           | (°) | lb(kg)                                    | lb(kg)      |
| Limited Free Lift<br>2 Stage Mast | XPDX50M265 | 104.3 (2650)     | 81.6 (2075)  | 150.3 (3820)   | 135.4 (3440)     | 5.9 (150)     | 5.9 (150)        | 5             | 10  | 8000 (3629)                               | 8820 (4000) |
|                                   | XPDX50M280 | 110.2 (2800)     | 84.6 (2150)  | 156.2 (3970)   | 141.3 (3590)     | 5.9 (150)     | 5.9 (150)        | 5             | 10  | 8000 (3629)                               | 8820 (4000) |
|                                   | XPDX50M300 | 118.1 (3000)     | 88.5 (2250)  | 164.1 (4170)   | 149.2 (3790)     | 5.9 (150)     | 5.9 (150)        | 5             | 10  | 8000 (3629)                               | 8820 (4000) |
|                                   | XPDX50M330 | 129.9 (3300)     | 94.4 (2400)  | 175.9 (4470)   | 161 (4090)       | 5.9 (150)     | 5.9 (150)        | 5             | 10  | 8000 (3629)                               | 8820 (4000) |
|                                   | XPDX50M370 | 145.6 (3700)     | 102.3 (2600) | 191.7 (4870)   | 176.7 (4490)     | 5.9 (150)     | 5.9 (150)        | 5             | 10  | 8000 (3629)                               | 8820 (4000) |
|                                   | XPDX50M400 | 157.4 (4000)     | 111.2 (2825) | 203.5 (5170)   | 189.9 (4825)     | 5.9 (150)     | 5.9 (150)        | 5             | 10  | 8000 (3629)                               | 8820 (4000) |
|                                   | XPDX50M450 | 177.1 (4500)     | 121 (3075)   | 223.2 (5670)   | 209.6 (5325)     | 5.9 (150)     | 5.9 (150)        | 5             | 6   | 8000 (3629)                               | 8820 (4000) |
|                                   | XPDX50M500 | 196.8 (5000)     | 133.8 (3400) | 242.9 (6170)   | 232.2 (5900)     | 5.9 (150)     | 5.9 (150)        | 5             | 6   | 8000 (3629)                               | 8820 (4000) |
|                                   | XPDX50M550 | 216.5 (5500)     | 143.7 (3650) | 262.5 (6670)   | 251.9 (6400)     | 5.9 (150)     | 5.9 (150)        | 5             | 6   | 7400 (3357)                               | 8820 (4000) |
|                                   | XPDX50M600 | 236.2 (6000)     | 153.5 (3900) | 282.2 (7170)   | 271.6 (6900)     | 5.9 (150)     | 5.9 (150)        | 5             | 6   | 7200 (3266)                               | 8158 (3700) |
| Full Free Lift<br>2 Stage Mast    | XPDX50U265 | 104.3 (2650)     | 81.6 (2075)  | 150.3 (3820)   | 133.8 (3400)     | 35.6 (905)    | 52.3 (1330)      | 5             | 10  | 8000 (3629)                               | 8820 (4000) |
|                                   | XPDX50U300 | 118.1 (3000)     | 88.5 (2250)  | 164.1 (4170)   | 147.6 (3750)     | 42.5 (1080)   | 59 (1500)        | 5             | 10  | 8000 (3629)                               | 8820 (4000) |
|                                   | XPDX50U330 | 129.9 (3300)     | 94.4 (2400)  | 175.9 (4470)   | 159.4 (4050)     | 48.4 (1230)   | 64.9 (1650)      | 5             | 10  | 8000 (3629)                               | 8820 (4000) |
|                                   | XPDX50U350 | 137.7 (3500)     | 98.4 (2500)  | 183.8 (4670)   | 167.3 (4250)     | 52.3 (1330)   | 66.9 (1700)      | 5             | 10  | 8000 (3629)                               | 8820 (4000) |
|                                   | XPDX50U370 | 145.6 (3700)     | 102.3 (2600) | 191.7 (4870)   | 175.1 (4450)     | 56.2 (1430)   | 70.8 (1800)      | 5             | 10  | 8000 (3629)                               | 8820 (4000) |
|                                   | XPDX50U400 | 157.4 (4000)     | 111.2 (2825) | 203.5 (5170)   | 189.9 (4825)     | 65.1 (1655)   | 78.7 (2000)      | 5             | 10  | 8000 (3629)                               | 8820 (4000) |
| Full Free Lift<br>3 Stage Mast    | XPDX50N400 | 157.4 (4000)     | 81.6 (2075)  | 202.7 (5150)   | 186 (4725)       | 35.6 (905)    | 52.3 (1330)      | 5             | 10  | 8000 (3629)                               | 8820 (4000) |
|                                   | XPDX50N425 | 167.3 (4250)     | 85.6 (2175)  | 213.3 (5420)   | 198.2 (5035)     | 39.5 (1005)   | 56.2 (1430)      | 5             | 6   | 8000 (3629)                               | 8820 (4000) |
|                                   | XPDX50N450 | 177.1 (4500)     | 88.5 (2250)  | 223.2 (5670)   | 206.6 (5250)     | 42.5 (1080)   | 59 (1500)        | 5             | 6   | 8000 (3629)                               | 8820 (4000) |
|                                   | XPDX50N470 | 185 (4700)       | 91.1 (2315)  | 231.1 (5870)   | 214.3 (5445)     | 45 (1145)     | 61.8 (1570)      | 5             | 6   | 8000 (3629)                               | 8820 (4000) |
|                                   | XPDX50N480 | 188.9 (4800)     | 94.4 (2400)  | 235 (5970)     | 224.4 (5700)     | 48.4 (1230)   | 59 (1500)        | 5             | 6   | 8000 (3629)                               | 8820 (4000) |
|                                   | XPDX50N500 | 196.8 (5000)     | 96.4 (2450)  | 242.9 (6170)   | 230.3 (5850)     | 50.3 (1280)   | 62.9 (1600)      | 5             | 6   | 7600 (3447)                               | 8820 (4000) |
|                                   | XPDX50N550 | 216.5 (5500)     | 102.3 (2600) | 262.5 (6670)   | 248 (6300)       | 56.2 (1430)   | 70.8 (1800)      | 5             | 6   | 7400 (3357)                               | 8820 (4000) |
|                                   | XPDX50N600 | 236.2 (6000)     | 111.2 (2825) | 282.2 (7170)   | 268.7 (6825)     | 65.1 (1655)   | 78.7 (2000)      | 5             | 6   | 7200 (3266)                               | 8158 (3700) |
|                                   | XPDX50N650 | 255.9 (6500)     | 121 (3075)   | 301.9 (7670)   | 290.3 (7375)     | 75 (1905)     | 86.6 (2200)      | 3             | 6   | 6800 (3084)                               | 7938 (3600) |
|                                   | XPDX50N700 | 275.5 (7000)     | 129.9 (3300) | 321.6 (8170)   | 314.9 (8000)     | 83.8 (2130)   | 90.5 (2300)      | 3             | 6   | 6000 (2722)                               | 7497 (3400) |

## 10,000lb XC Series Mast Specification

| Type                              | Model      | Max. Fork Height | Lowered      | Overall Height |                  | Free Lift     |                  | Tilting Range |     | Load Capacity<br>10,000lbs at 24" or 600mm |              |
|-----------------------------------|------------|------------------|--------------|----------------|------------------|---------------|------------------|---------------|-----|--|--------------|
|                                   |            |                  |              | With Backrest  | Without Backrest | With Backrest | Without Backrest | F             | R   | Single Tire                                | Dual Tire    |
|                                   |            |                  |              | in(mm)         | in(mm)           | in(mm)        | in(mm)           | (°)           | (°) | lb(kg)                                     | lb(kg)       |
| Limited Free Lift<br>2 Stage Mast | XPDX50M265 | 104.3 (2650)     | 81.6 (2075)  | 150.3 (3820)   | 135.4 (3440)     | 5.9 (150)     | 5.9 (150)        | 5             | 10  | 10000 (4527)                               | 10000 (4527) |
|                                   | XPDX50M280 | 110.2 (2800)     | 84.6 (2150)  | 156.2 (3970)   | 141.3 (3590)     | 5.9 (150)     | 5.9 (150)        | 5             | 10  | 10000 (4527)                               | 10000 (4527) |
|                                   | XPDX50M300 | 118.1 (3000)     | 88.5 (2250)  | 164.1 (4170)   | 149.2 (3790)     | 5.9 (150)     | 5.9 (150)        | 5             | 10  | 10000 (4527)                               | 10000 (4527) |
|                                   | XPDX50M330 | 129.9 (3300)     | 94.4 (2400)  | 175.9 (4470)   | 161 (4090)       | 5.9 (150)     | 5.9 (150)        | 5             | 10  | 10000 (4527)                               | 10000 (4527) |
|                                   | XPDX50M370 | 145.6 (3700)     | 102.3 (2600) | 191.7 (4870)   | 176.7 (4490)     | 5.9 (150)     | 5.9 (150)        | 5             | 10  | 10000 (4527)                               | 10000 (4527) |
|                                   | XPDX50M400 | 157.4 (4000)     | 111.2 (2825) | 203.5 (5170)   | 189.9 (4825)     | 5.9 (150)     | 5.9 (150)        | 5             | 10  | 10000 (4527)                               | 10000 (4527) |
|                                   | XPDX50M450 | 177.1 (4500)     | 121 (3075)   | 223.2 (5670)   | 209.6 (5325)     | 5.9 (150)     | 5.9 (150)        | 5             | 6   | 10000 (4527)                               | 10000 (4527) |
|                                   | XPDX50M500 | 196.8 (5000)     | 133.8 (3400) | 242.9 (6170)   | 232.2 (5900)     | 5.9 (150)     | 5.9 (150)        | 5             | 6   | 9400 (4264)                                | 10000 (4527) |
|                                   | XPDX50M550 | 216.5 (5500)     | 143.7 (3650) | 262.5 (6670)   | 251.9 (6400)     | 5.9 (150)     | 5.9 (150)        | 5             | 6   | 8800 (3992)                                | 9400 (4264)  |
|                                   | XPDX50M600 | 236.2 (6000)     | 153.5 (3900) | 282.2 (7170)   | 271.6 (6900)     | 5.9 (150)     | 5.9 (150)        | 5             | 6   | 8000 (3629)                                | 8400 (3810)  |
| Full Free Lift<br>2 Stage Mast    | XPDX50U265 | 104.3 (2650)     | 81.6 (2075)  | 150.3 (3820)   | 133.8 (3400)     | 35.6 (905)    | 52.3 (1330)      | 5             | 10  | 10000 (4527)                               | 10000 (4527) |
|                                   | XPDX50U300 | 118.1 (3000)     | 88.5 (2250)  | 164.1 (4170)   | 147.6 (3750)     | 42.5 (1080)   | 59 (1500)        | 5             | 10  | 10000 (4527)                               | 10000 (4527) |
|                                   | XPDX50U330 | 129.9 (3300)     | 94.4 (2400)  | 175.9 (4470)   | 159.4 (4050)     | 48.4 (1230)   | 64.9 (1650)      | 5             | 10  | 10000 (4527)                               | 10000 (4527) |
|                                   | XPDX50U350 | 137.7 (3500)     | 98.4 (2500)  | 183.8 (4670)   | 167.3 (4250)     | 52.3 (1330)   | 66.9 (1700)      | 5             | 10  | 10000 (4527)                               | 10000 (4527) |
|                                   | XPDX50U370 | 145.6 (3700)     | 102.3 (2600) | 191.7 (4870)   | 175.1 (4450)     | 56.2 (1430)   | 70.8 (1800)      | 5             | 10  | 10000 (4527)                               | 10000 (4527) |
|                                   | XPDX50U400 | 157.4 (4000)     | 111.2 (2825) | 203.5 (5170)   | 189.9 (4825)     | 65.1 (1655)   | 78.7 (2000)      | 5             | 10  | 10000 (4527)                               | 10000 (4527) |
| Full Free Lift<br>3 Stage Mast    | XPDX50N400 | 157.4 (4000)     | 81.6 (2075)  | 202.7 (5150)   | 186 (4725)       | 35.6 (905)    | 52.3 (1330)      | 5             | 10  | 10000 (4527)                               | 10000 (4527) |
|                                   | XPDX50N425 | 167.3 (4250)     | 85.6 (2175)  | 213.3 (5420)   | 198.2 (5035)     | 39.5 (1005)   | 56.2 (1430)      | 5             | 6   | 10000 (4527)                               | 10000 (4527) |
|                                   | XPDX50N450 | 177.1 (4500)     | 88.5 (2250)  | 223.2 (5670)   | 206.6 (5250)     | 42.5 (1080)   | 59 (1500)        | 5             | 6   | 9600 (4354)                                | 10000 (4527) |
|                                   | XPDX50N470 | 185 (4700)       | 91.1 (2315)  | 231.1 (5870)   | 214.3 (5445)     | 45 (1145)     | 61.8 (1570)      | 5             | 6   | 9400 (4264)                                | 9600 (4354)  |
|                                   | XPDX50N480 | 188.9 (4800)     | 94.4 (2400)  | 235 (5970)     | 224.4 (5700)     | 48.4 (1230)   | 59 (1500)        | 5             | 6   | 9400 (4264)                                | 9600 (4354)  |
|                                   | XPDX50N500 | 196.8 (5000)     | 96.4 (2450)  | 242.9 (6170)   | 230.3 (5850)     | 50.3 (1280)   | 62.9 (1600)      | 5             | 6   | 9000 (4082)                                | 9400 (4264)  |
|                                   | XPDX50N550 | 216.5 (5500)     | 102.3 (2600) | 262.5 (6670)   | 248 (6300)       | 56.2 (1430)   | 70.8 (1800)      | 5             | 6   | 8800 (3992)                                | 9000 (4082)  |
|                                   | XPDX50N600 | 236.2 (6000)     | 111.2 (2825) | 282.2 (7170)   | 268.7 (6825)     | 65.1 (1655)   | 78.7 (2000)      | 5             | 6   | 8200 (3719)                                | 8800 (3992)  |
|                                   | XPDX50N650 | 255.9 (6500)     | 121 (3075)   | 301.9 (7670)   | 290.3 (7375)     | 75 (1905)     | 86.6 (2200)      | 3             | 6   | 7800 (3538)                                | 8200 (3719)  |
|                                   | XPDX50N700 | 275.5 (7000)     | 129.9 (3300) | 321.6 (8170)   | 314.9 (8000)     | 83.8 (2130)   | 90.5 (2300)      | 3             | 6   | 7000 (3175)                                | 7600 (3447)  |

## 9,000lb XC Series Mast Specification

| Type                              | Model      | Max. Fork Height | Lowered      | Overall Height |                  | Free Lift     |                  | Tilting Range |     | Load Capacity<br>9,000lbs at 24" or 600mm |             |
|-----------------------------------|------------|------------------|--------------|----------------|------------------|---------------|------------------|---------------|-----|---|-------------|
|                                   |            |                  |              | With Backrest  | Without Backrest | With Backrest | Without Backrest | F             | R   | Single Tire                               | Dual Tire   |
|                                   |            |                  |              | in(mm)         | in(mm)           | in(mm)        | in(mm)           | (°)           | (°) | lb(kg)                                    | lb(kg)      |
| Limited Free Lift<br>2 Stage Mast | XPDX50M265 | 104.3 (2650)     | 81.6 (2075)  | 150.3 (3820)   | 135.4 (3440)     | 5.9 (150)     | 5.9 (150)        | 5             | 10  | 9000 (4082)                               | 9000 (4082) |
|                                   | XPDX50M280 | 110.2 (2800)     | 84.6 (2150)  | 156.2 (3970)   | 141.3 (3590)     | 5.9 (150)     | 5.9 (150)        | 5             | 10  | 9000 (4082)                               | 9000 (4082) |
|                                   | XPDX50M300 | 118.1 (3000)     | 88.5 (2250)  | 164.1 (4170)   | 149.2 (3790)     | 5.9 (150)     | 5.9 (150)        | 5             | 10  | 9000 (4082)                               | 9000 (4082) |
|                                   | XPDX50M330 | 129.9 (3300)     | 94.4 (2400)  | 175.9 (4470)   | 161 (4090)       | 5.9 (150)     | 5.9 (150)        | 5             | 10  | 9000 (4082)                               | 9000 (4082) |
|                                   | XPDX50M370 | 145.6 (3700)     | 102.3 (2600) | 191.7 (4870)   | 176.7 (4490)     | 5.9 (150)     | 5.9 (150)        | 5             | 10  | 9000 (4082)                               | 9000 (4082) |
|                                   | XPDX50M400 | 157.4 (4000)     | 111.2 (2825) | 203.5 (5170)   | 189.9 (4825)     | 5.9 (150)     | 5.9 (150)        | 5             | 10  | 9000 (4082)                               | 9000 (4082) |
|                                   | XPDX50M450 | 177.1 (4500)     | 121 (3075)   | 223.2 (5670)   | 209.6 (5325)     | 5.9 (150)     | 5.9 (150)        | 5             | 6   | 9000 (4082)                               | 9000 (4082) |
|                                   | XPDX50M500 | 196.8 (5000)     | 133.8 (3400) | 242.9 (6170)   | 232.2 (5900)     | 5.9 (150)     | 5.9 (150)        | 5             | 6   | 8800 (3992)                               | 8800 (3992) |
|                                   | XPDX50M550 | 216.5 (5500)     | 143.7 (3650) | 262.5 (6670)   | 251.9 (6400)     | 5.9 (150)     | 5.9 (150)        | 5             | 6   | 8000 (3629)                               | 8400 (3810) |
|                                   | XPDX50M600 | 236.2 (6000)     | 153.5 (3900) | 282.2 (7170)   | 271.6 (6900)     | 5.9 (150)     | 5.9 (150)        | 5             | 6   | 7200 (3266)                               | 7600 (3447) |
| Full Free Lift<br>2 Stage Mast    | XPDX50U265 | 104.3 (2650)     | 81.6 (2075)  | 150.3 (3820)   | 133.8 (3400)     | 35.6 (905)    | 52.3 (1330)      | 5             | 10  | 9000 (4082)                               | 9000 (4082) |
|                                   | XPDX50U300 | 118.1 (3000)     | 88.5 (2250)  | 164.1 (4170)   | 147.6 (3750)     | 42.5 (1080)   | 59 (1500)        | 5             | 10  | 9000 (4082)                               | 9000 (4082) |
|                                   | XPDX50U330 | 129.9 (3300)     | 94.4 (2400)  | 175.9 (4470)   | 159.4 (4050)     | 48.4 (1230)   | 64.9 (1650)      | 5             | 10  | 9000 (4082)                               | 9000 (4082) |
|                                   | XPDX50U350 | 137.7 (3500)     | 98.4 (2500)  | 183.8 (4670)   | 167.3 (4250)     | 52.3 (1330)   | 66.9 (1700)      | 5             | 10  | 9000 (4082)                               | 9000 (4082) |
|                                   | XPDX50U370 | 145.6 (3700)     | 102.3 (2600) | 191.7 (4870)   | 175.1 (4450)     | 56.2 (1430)   | 70.8 (1800)      | 5             | 10  | 9000 (4082)                               | 9000 (4082) |
|                                   | XPDX50U400 | 157.4 (4000)     | 111.2 (2825) | 203.5 (5170)   | 189.9 (4825)     | 65.1 (1655)   | 78.7 (2000)      | 5             | 10  | 9000 (4082)                               | 9000 (4082) |
| Full Free Lift<br>3 Stage Mast    | XPDX50N400 | 157.4 (4000)     | 81.6 (2075)  | 202.7 (5150)   | 186 (4725)       | 35.6 (905)    | 52.3 (1330)      | 5             | 10  | 9000 (4082)                               | 9000 (4082) |
|                                   | XPDX50N425 | 167.3 (4250)     | 85.6 (2175)  | 213.3 (5420)   | 198.2 (5035)     | 39.5 (1005)   | 56.2 (1430)      | 5             | 6   | 9000 (4082)                               | 9000 (4082) |
|                                   | XPDX50N450 | 177.1 (4500)     | 88.5 (2250)  | 223.2 (5670)   | 206.6 (5250)     | 42.5 (1080)   | 59 (1500)        | 5             | 6   | 8800 (3992)                               | 9000 (4082) |
|                                   | XPDX50N47  |                  |              |                |                  |               |                  |               |     |   |             |

# 8,000-11,000lb XC Series 4 Wheel Electric Pneumatic Forklift with Lithium-ion Technology

| Distinguishing Marks | HANGCHA GROUP CO.,LTD.  |  |                               |                       |                         |                        |                         |                         |
|----------------------|---|--|-------------------------------|-----------------------|-------------------------|------------------------|-------------------------|-------------------------|
|                      |   |  | FB40Li                        | FB45Li                | FB50Li                  | FBL50Li                |                         |                         |
| 1.1                  | Manufacturer  |  | FB40Li                        | FB45Li                | FB50Li                  | FBL50Li                |                         |                         |
|                      | HCFA Model Designation  |  | CPD40-XD4-SI28                | CPD45-XD4-SI28        | CPD50-XXD4-SI28         | CPD50-XD4-SI28         |                         |                         |
| 1.2                  | Manufacturers Type Designation                                  |  | Electric                      | Electric              | Electric                | Electric               |                         |                         |
| 1.3                  | Drive: electric (battery or mains), diesel, petrol, fuel gas    |  | Seated                        | Seated                | Seated                  | Seated                 |                         |                         |
| 1.4                  | Operator Type: hand, pedestrian, standing, seated, order-picker |  |                               |                       |                         |                        |                         |                         |
| 1.5                  | Load Capacity/Rated Load  | Q  | lb (kg)                       | 8000(3628)            | 9000(4082)              | 10000(4535)            | 11000(4990)             |                         |
| 1.6                  | Load Centre Distance  | c  | in (mm)                       | 24(600)               | 24(600)                 | 24(600)                | 24(600)                 |                         |
| 1.7                  | Load Distance, centre of drive axle to fork                     | x  | in (mm)                       | 20.5(520)             | 20.5(520)               | 20.5(520)              | 20.7(525)               |                         |
| 1.8                  | Wheelbase   | y  | in (mm)                       | 76.8(1950)            | 76.8(1950)              | 76.8(1950)             | 76.8(1950)              |                         |
| Weight               | 2.1   | Service Weight   | lb (kg)                       | 12855(5830)           | 13670(6200)             | 15145(6870)            | 15765(7150)             |                         |
|                      | 2.2   | Axle Loading, laden front/rear                               | lb (kg)                       | 17880/3792(8110/1720) | 21000/2590(9525/1175)   | 23268/2901(10554/1316) | 23832/2954(10810/1340)  |                         |
|                      | 2.3   | Axle Loading, unladen front/rear                             | lb (kg)                       | 5787/7064(2625/3204)  | 6151/7518(2790/3410)    | 6393/8752(2900/3970)   | 6460/9304(2930/4220)    |                         |
| Tires, chassis       | 3.1   | Tires: solid rubber, super elastic, pneumatic, polyurethane  |                               | Pneumatic             | Pneumatic               | Pneumatic              | Pneumatic               |                         |
|                      | 3.2   | Tire size, front   |                               | 250-15                | 250-15                  | 28×12.5 - 15           | 28×12.5 - 15            |                         |
|                      | 3.3   | Tire size, rear  |                               | 23×9 - 10             | 23×9 - 10               | 23×9 - 12              | 23×9 - 12               |                         |
|                      | 3.4   | Wheels, number front rear (x = driven wheels)                |                               | 2×/2                  | 2×/2                    | 2×/2                   | 2×/2                    |                         |
|                      | 3.5   | Tread, front   | b10                           | in (mm)               | 44(1118)                | 44(1118)               | 45.5(1155)              | 45.5(1155)              |
|                      | 3.6   | Tread, rear  | b11                           | in (mm)               | 43.7(1110)              | 43.7(1110)             | 43.7(1110)              | 43.7(1110)              |
| Dimensions           | 4.1   | Tilt of Mast/fork carriage forward/backward                  | α/β                           | (°)                   | 5/10                    | 5/10                   | 5/10                    | 5/10                    |
|                      | 4.2   | Height, mast lowered   | h1                            | in (mm)               | 86(2185)                | 86(2185)               | 86(2185)                | 86(2185)                |
|                      | 4.3   | Free Lift  | h2                            | in (mm)               | 5.9(150)                | 5.9(150)               | 5.9(150)                | 5.9(150)                |
|                      | 4.4   | Lift   | h3                            | in (mm)               | 118.1(3000)             | 118.1(3000)            | 118.1(3000)             | 118.1(3000)             |
|                      | 4.5   | Height, mast extended  | h4                            | in (mm)               | 164(4170)               | 164(4170)              | 164(4170)               | 164(4170)               |
|                      | 4.6   | Height of Overhead Guard STD.                                | h6                            | in (mm)               | 87.4(2220)              | 87.4(2220)             | 87.4(2220)              | 87.4(2220)              |
|                      | 4.7   | Coupling Height  | h10                           | in (mm)               | 20.9(530)               | 20.9(530)              | 20.9(530)               | 20.9(530)               |
|                      | 4.8   | Overall Length   | l1                            | in (mm)               | 154(3911)               | 154(3911)              | 154.1(3916)             | 154.4(3921)             |
|                      | 4.9   | Length to Face of Forks                                      | l2                            | in (mm)               | 111.8(2841)             | 111.8(2841)            | 112(2846)               | 112.2(2851)             |
|                      | 4.21  | Overall Width  | b1                            | in (mm)               | 53.8(1368)              | 53.8(1368)             | 57.4(1458)              | 57.4(1458)              |
|                      | 4.22  | Fork Dimensions  | s/e/l                         | in (mm)               | 2*4.8*42.1(50*122*1070) | 2*6*42.1(50*150*1070)  | 2.2*6*42.1(55*150*1070) | 2.4*6*42.1(60*150*1070) |
|                      | 4.23  | Fork Carriage DIN 15 173 --- ISO 2328, class/type A,B        |                               |                       | ISO 2328 3A             | ISO 2328 3A            | ISO 2328 3A             | ISO 2328 3A             |
|                      | 4.24  | Fork Carriage Width  | b3                            | in (mm)               | 49.2(1250)              | 49.2(1250)             | 49.2(1250)              | 49.2(1250)              |
|                      | 4.25  | Distance between Fork Arms                                   | b5                            | in (mm)               | 12.2/49.2(310/1250)     | 12.2/49.2(310/1250)    | 12.2/49.2(310/1250)     | 12.2/49.2(310/1250)     |
|                      | 4.31  | Ground Clearance, laden, below mast                          | m1                            | in (mm)               | 5.9(150)                | 5.9(150)               | 5.9(150)                | 5.9(150)                |
|                      | 4.32  | Ground Clearance, centre of wheelbase                        | m2                            | in (mm)               | 5.9(150)                | 5.9(150)               | 5.9(150)                | 5.9(150)                |
|                      | 4.33  | Aisle Width for Pallets 39" x 47" Crossways                  | As1                           | in (mm)               | 168.1(4270)             | 168.1(4270)            | 168.3(4275)             | 168.5(4280)             |
|                      | 4.34  | Aisle Width for Pallets 31.5" x 47" Lengthways               | As2                           | in (mm)               | 160.2(4070)             | 160.2(4070)            | 160.4(4075)             | 160.6(4080)             |
|                      | 4.35  | Turning Radius   | Wa                            | in (mm)               | 100.4(2550)             | 100.4(2550)            | 100.4(2550)             | 100.4(2550)             |
|                      | 4.36  | Internal Turning Radius                                      | b13                           | in (mm)               | 28.7(730)               | 28.7(730)              | 28.7(730)               | 28.7(730)               |
|                      | Performance Data  | 5.1  | Travel Speed, laden/unladen   | mph (km/h)            | 11.2/11.2(18/18)        | 11.2/11.2(18/18)       | 11.2/11.2(18/18)        | 11.2/11.2(18/18)        |
|                      |   | 5.2  | Lift Speed, laden/unladen     | fpm (m/s)             | 68.9/84.6(0.350/0.430)  | 68.9/84.6(0.350/0.430) | 68.9/84.6(0.350/0.430)  | 65/84.6(0.330/0.430)    |
|                      |   | 5.3  | Lowering Speed, laden/unladen | fpm (m/s)             | 84.6/94.5(0.430/0.480)  | 84.6/94.5(0.430/0.480) | 84.6/94.5(0.430/0.480)  | 84.6/94.5(0.430/0.480)  |
|                      |   | 5.4  | Drawbar Pull, laden/unladen   | lbf (N)               | 4181/4496(18600/20000)  | 4226/4541(18800/20200) | 4496/4631(20000/20600)  | 4564/4676(20300/20800)  |
| 5.5                  |   | Max. Drawbar Pull, laden/unladen                             | lbf (N)                       | 5170(23000)           | 5395(24000)             | 5845(26000)            | 6295(28000)             |                         |
| 5.6                  |   | Gradeability, laden/unladen                                  | %                             | 15/20                 | 15/20                   | 15/20                  | 15/20                   |                         |
| 5.7                  |   | Acceleration Time, laden/unladen (0-394°)                    | s                             | 5.0/4.8               | 5.2/5.0                 | 5.6/5.3                | 5.8/5.4                 |                         |
| 5.8                  |   | Service Brake  |                               | Hydraulic             | Hydraulic               | Hydraulic              | Hydraulic               |                         |
| 5.9                  |   | Parking Brake  |                               | Mechanical            | Mechanical              | Mechanical             | Mechanical              |                         |
| Electric Motor       | 6.1   | Drive Motor Rating S2 60 min                                 | HP (kW)                       | 30.8(23)              | 30.8(23)                | 30.8(23)               | 30.8(23)                |                         |
|                      | 6.2   | Lift Motor Rating at S3 15%                                  | HP (kW)                       | 37.5(28)              | 37.5(28)                | 37.5(28)               | 37.5(28)                |                         |
|                      | 6.3   | Battery Voltage, Std   | V/Ah                          | 80/542                | 80/542                  | 80/542                 | 80/542                  |                         |
|                      | 6.4   | Standard Weight of Lithium Iron Phosphate Battery            | lb (kg)                       | 948(430)              | 948(430)                | 948(430)               | 948(430)                |                         |
|                      | 6.5   | Min. Battery Weight  | lb (kg)                       | 948(430)              | 948(430)                | 948(430)               | 948(430)                |                         |
|                      | 6.6   | Max. Battery Weight  | lb (kg)                       | 1323(600)             | 1323(600)               | 1323(600)              | 1323(600)               |                         |
| Additional Data      | 8.1   | Type of Drive Control  |                               | MOSFET/AC             | MOSFET/AC               | MOSFET/AC              | MOSFET/AC               |                         |
|                      |   | Manufacturer   |                               | INMOTION              | INMOTION                | INMOTION               | INMOTION                |                         |
|                      |   | Control Model  |                               | ACS80XL-550C          | ACS80XL-550C            | ACS80XL-550C           | ACS80XL-550C            |                         |
|                      | 8.2   | Operating Pressure for Attachments                           | psi (bar)                     | 2683(185)             | 2683(185)               | 2683(185)              | 2683(185)               |                         |
|                      | 8.3   | Oil Volume for Attachments                                   | l/min                         | 65                    | 65                      | 65                     | 65                      |                         |
|                      | 8.4   | Sound Level at the Driver's Ear According to EN / DIN 12 053 | dB (A)                        | 75                    | 75                      | 75                     | 75                      |                         |
|                      | 8.5   | Towing Coupling, type DIN                                    |                               | φ35 Pin               | φ35 Pin                 | φ35 Pin                | φ35 Pin                 |                         |
|                      | 9.1   | Hydraulic Tank - capacity (drain & refill)                   | liter                         | 46                    | 46                      | 46                     | 46                      |                         |

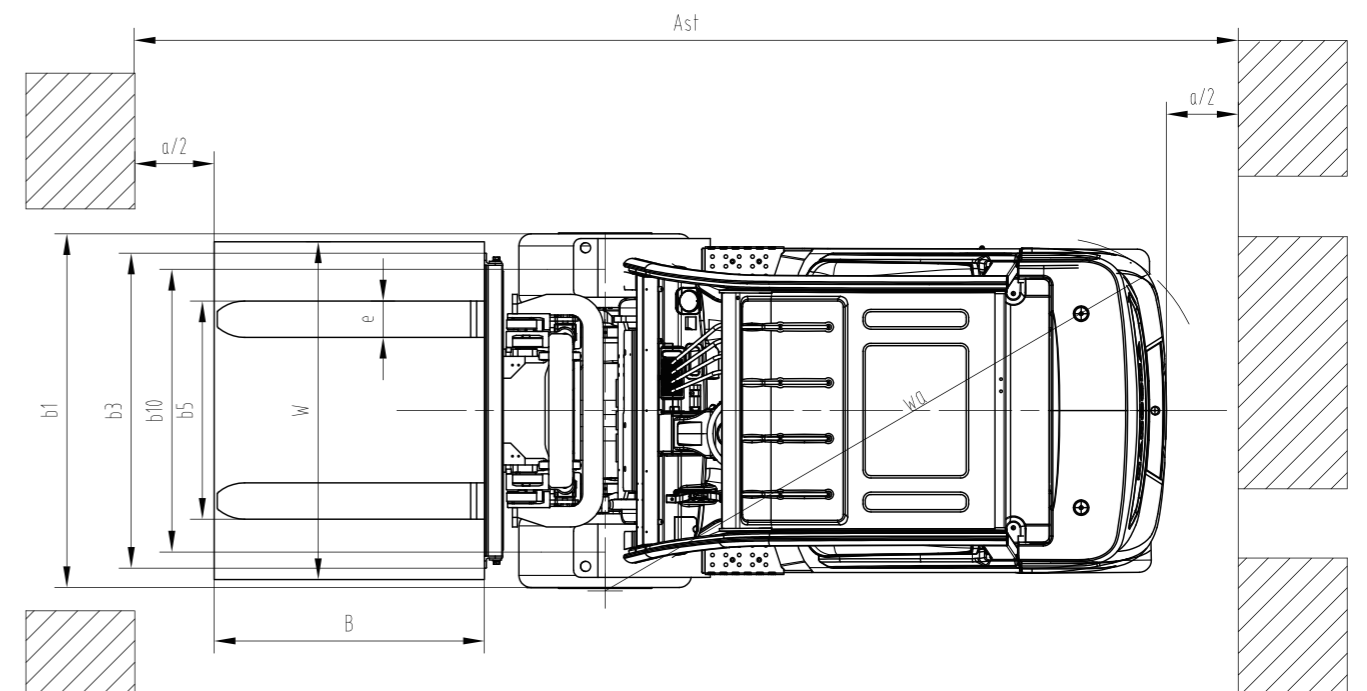
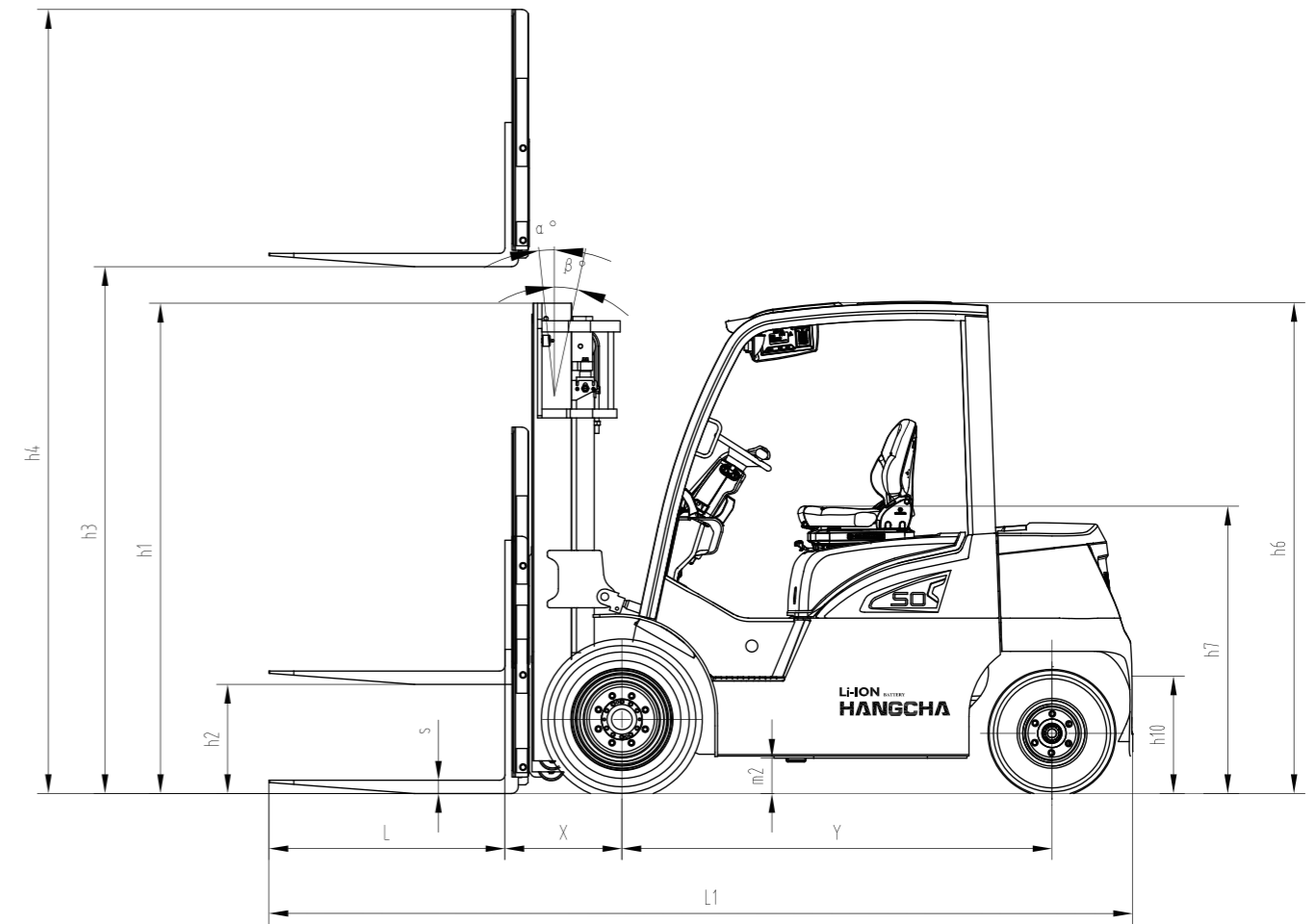

a=7.9inch  
AST=a+Wa+ X+B