

Move More Loads Faster, Minimize Damage and Stay Competitive

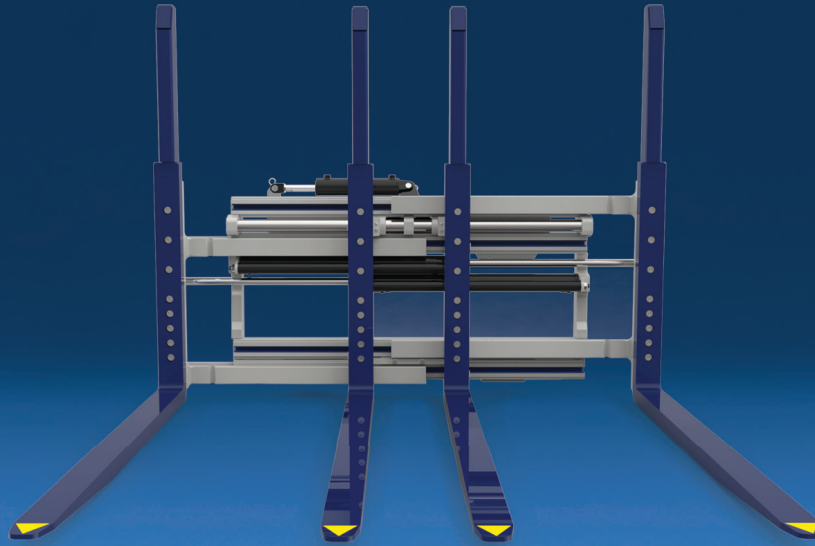

Adjustable fork stop blocks to fit different pallet sizes

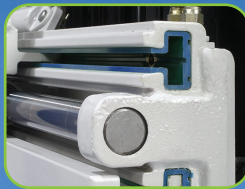

Fully enclosed wrap around UHMW bearings



Bolt-on interchangeable forks

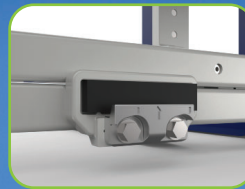

Dual class II or III mountings



RapidSync™ option for ultra fast equal fork movement

APPLICATIONS

Designed for any application using pallets or containers to transport product, Cascade's Single-Double Pallet Handler allows single pallet handling without protrusion outside the truck profile. Spreading the forks hydraulically allows handling of two pallets side by side. Sideshifting provides added flexibility for aligning forks or pallets in tight areas.

FEATURES

- Superior visibility through and over the frame for damage free handling at all stacking heights.
- All steel frame for increased overall durability, eliminating flexing.
- Easy access cylinders for quick servicing.
- Bolt-on Interchangeable forks for low service cost.
- Full-length, fully enclosed wrap around UHMW plastic bearings provide maximum strength and support, greatly reducing wear on bearing surface.
- Dual class II and III mountings, easily field converted.
- Inner forks mounted on a chrome pin for greater inner fork stability.
- Adjustable fork set spread for ability to handle different types of pallets.

OPTIONS

- Cascade **RapidSync™** for ultra fast perfectly synchronized fork positioning.
- Various load backrest configuration heights, fork lengths and sections.
- Various fork set spreads and opening ranges.
- Quick-disconnect lower hooks.
- Drop shank forks—forks are lowered relative to the attachment frame.
- Independent fork set control—allows moving left or right fork set independent of the opposite fork set.
- Non-Sideshifting models available.

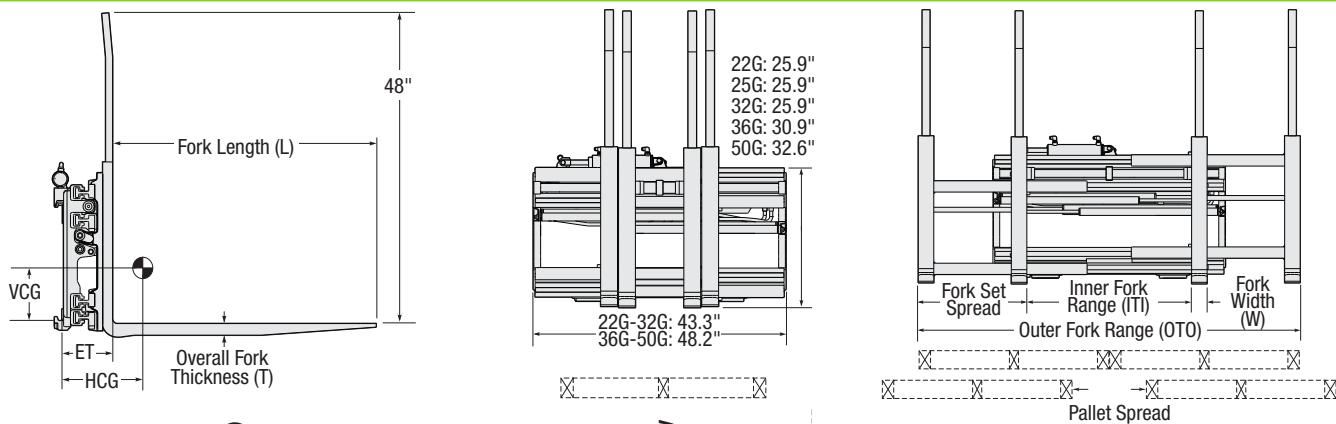

Catalog Order No.	Capacity@ 24" (600 mm) Load Center		Mtg. Class	Min. Truck Carriage Width	Weight	Effective Thickness	Horizontal Ctr. Of Gravity	Vertical Ctr. of Gravity	Inner Fork Range	Outer Fork Range	Avg. Pallet Spread	Fork Set Spread	Fork Size	
	lbs	kg												LxWxT
36" x 36" Beverage Pallets														
25G-FDS-A005	5,500	2,500	II	34.3"	1,080	490	8.9"	7.7"	10.9"	13.0-32.1"	26.0-80.1"	20.0"	24.0"	36.0" x 3.2" x 1.8"
25G-FDS-B005	5,500	2,500	III	34.3"	1,075	488	8.7"	7.5"	11.2"	13.0-32.1"	26.0-80.1"	20.0"	24.0"	36.0" x 3.2" x 1.8"
32G-FDS-B005	7,000	3,200	III	34.3"	1,130	513	8.9"	7.9"	11.6"	13.0-32.1"	26.0-80.1"	20.0"	24.0"	36.0" x 3.2" x 2.0"
36G-FDS-B005	8,000	3,600	III	43.0"	1,550	700	10.2"	8.2"	12.5"	13.0-32.1"	26.0-80.1"	20.0"	24.0"	36.0" x 3.2" x 2.4"
50G-FDS-C005	10,000	5,000	IV	43.0"	1,575	715	10.2"	8.0"	11.2"	13.0-32.1"	26.0-80.1"	20.0"	24.0"	36.0" x 3.2" x 2.4"
48" x 40" Block and GMA Pallets ①②														
10H-FDS-2A-0100	2,200	1,000	II	38.2"	926	420	8.7"	8.7"	13.9"	11.2"-26.8"	24.2"-70.9"	9.5"	22.0"	42.0" x 3.2" x 1.2"
22G-FDS-A221	4,800	2,200	II	34.3"	1,125	510	8.7"	8.0"	10.8"	14.6-28.7"	27.6-82.7"	15.0"	27.0"	42.0" x 3.2" x 1.6"
22G-FDS-B221	4,800	2,200	III	34.3"	1,125	510	8.5"	7.8"	11.1"	14.6-28.7"	27.6-82.7"	15.0"	27.0"	42.0" x 3.2" x 1.6"
25G-FDS-A221	5,500	2,500	II	34.3"	1,170	531	8.9"	8.4"	10.8"	14.6-28.7"	27.6-82.7"	15.0"	27.0"	42.0" x 3.2" x 1.8"
25G-FDS-B221	5,500	2,500	III	34.3"	1,160	526	8.7"	8.2"	11.1"	14.6-28.7"	27.6-82.7"	15.0"	27.0"	42.0" x 3.2" x 1.8"
32G-FDS-B221	7,000	3,200	III	34.3"	1,205	547	8.9"	8.8"	10.7"	14.6-28.7"	27.6-82.7"	15.0"	27.0"	42.0" x 3.2" x 2.0"
36G-FDS-B221	8,000	3,600	III	43.0"	1,635	740	10.2"	9.1"	12.1"	14.6-28.7"	27.6-82.7"	15.0"	27.0"	42.0" x 3.2" x 2.4"
36G-FDS-C221	8,000	3,600	IV	43.0"	1,652	749	10.2"	9.0"	10.4"	14.6-28.7"	27.6-82.7"	15.0"	27.0"	42.0" x 3.2" x 2.4"
50G-FDS-C221	10,000	5,000	IV	43.0"	1,655	750	10.2"	9.0"	10.4"	14.6-28.7"	27.6-82.7"	15.0"	27.0"	42.0" x 3.2" x 2.4"
60G-FDS-4A-0010	13,225	6,000	IV	64.0"	2,549	1,156	11.3"	7.6"	12.4"	7.1" - 33.2"	22.1" - 77.2"	15.0"	22.1"	48" x 3.9"/3.5" x 2.6"
44" x 56" Container Pallets														
25G-FDS-A013	5,500	2,500	II	34.3"	1,195	542	8.9"	11.3"	9.7"	13.0-28.1"	26.0-80.1"	11.0"	26.0"	54.0" x 3.2" x 1.8"
25G-FDS-B013	5,500	2,500	III	34.3"	1,185	538	8.7"	11.2"	10.0"	13.0-28.1"	26.0-80.1"	11.0"	26.0"	54.0" x 3.2" x 1.8"
32G-FDS-B013	7,000	3,200	III	34.3"	1,255	569	8.9"	11.8"	10.2"	13.0-28.1"	26.0-80.1"	11.0"	26.0"	54.0" x 3.2" x 2.0"
36G-FDS-B013	8,000	3,600	III	43.0"	1,700	775	10.2"	11.6"	11.4"	13.0-28.1"	26.0-80.1"	11.0"	26.0"	54.0" x 3.2" x 2.4"
36G-FDS-C013	8,000	3,600	IV	43.0"	1,722	781	10.2"	11.5"	10.0"	13.0-28.1"	26.0-80.1"	11.0"	26.0"	54.0" x 3.2" x 2.4"
50G-FDS-C013	10,000	5,000	IV	43.0"	1,725	785	10.2"	11.5"	10.0"	13.0-28.1"	26.0-80.1"	11.0"	26.0"	54.0" x 3.2" x 2.4"

- ① This model can handle GMA type stringer and block pallets, including Chop Type III and Mark 55 pallets in both directions. The single-mode fork positioning range is 15.0" to 21.0" in-to-in, or 27.6" to 33.6" out-to-out. Average pallet spread is 8.0" for both pallets. No additional truck auxiliary valves required, beyond the normal two auxiliary valves.
- ② Dedicated GMA Only models available, consult Cascade.
- ③ Available with the Cascade RapidSync™ option for increased fork positioning speed and perfect fork synchronization. Consult Cascade for additional details.

- ▶ Cascade units come standard with bronze sideshift bearings and bronze lower hooks.
- ▶ Other fork lengths available.
- ▶ FDS unit limited to 60" fork length maximum. For longer forks see FQS units
- ▶ The outer fork tines are .2" higher than the inner fork tines.

- ▶ Plastic pallets may require modified fork dimensions. For other ranges or fork dimensions, Consult Cascade.
- ▶ 8" (200 mm) total sideshift.
- ▶ Right hand termination standard, left hand termination

HYDRAULIC FLOW & PRESSURE

Minimum	Recommended	Maximum	Operating Pressure
15 l/min.	27 l/min.	27 l/min.	200 bar

HYDRAULIC FUNCTIONS

Hydraulic Functions	Truck Auxiliary Valves Required
2	2

Cascade Corporation • PO Box 20187 • Portland, OR 97294-0187 • USA • 800 CASCADE (227.2233) • Tel 503.669.6257 • Fax 800.693.3768 • Fax 503.669.6367
 Cascade Canada Ltd. • 5570 Timberlea Blvd. • Mississauga, Ontario L4W 4M6 • Canada • 800.380.2272 • Tel 905.629.7777 • Fax 905.629.7785